

# High speed transmission, 1mm pitch Small Interface Connector

## DH Series

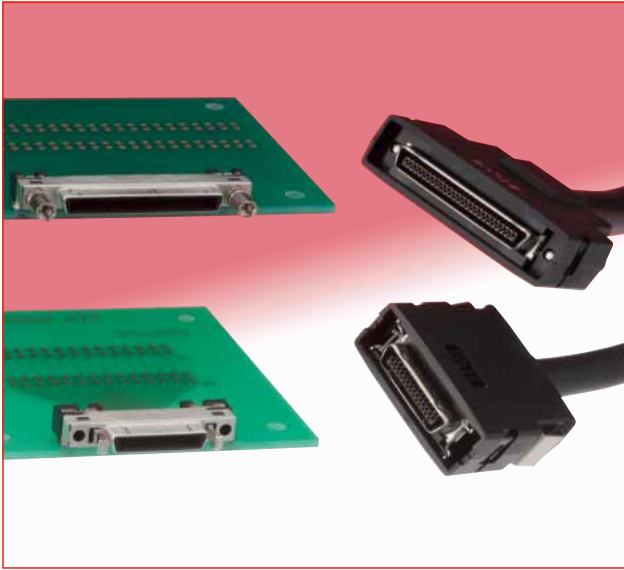

### Overview

DH Series is an impedance controlled interface connector for high speed transmission.

1mm contact mating pitch together with a 0.5mm mounting pitch yields a more compact, lower profile, higher density alternate to conventional half pitch interface connectors.

4 different lock styles are available to meet various applications.

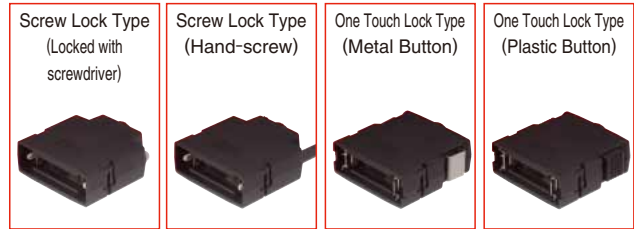

### Features

#### 1. Small Design

Mating face area  
**Approx 50% reduced**

**DXM Series**  
(Conventional-general purpose half pitch type)

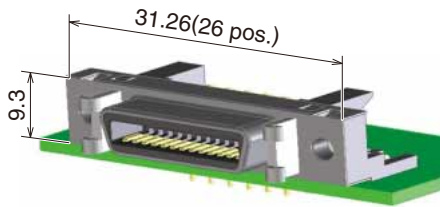

Mating pitch: 1.27mm

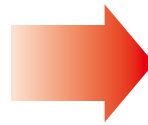

**DH Series**

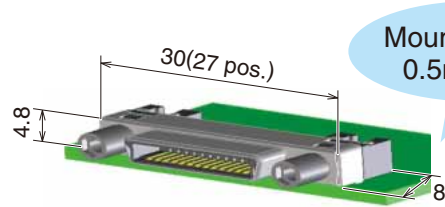

Mating pitch: 1.0mm

#### 2. Robust design

Receptacle



##### PCB Retention Force

Through hole mounting for shell and metal fitting increases PCB retention force.

**Robust design resists wrenching D-shaped opening.**

Plug



**Secure Panel Attachment (optional)**  
with easy to use hexagon sockets.

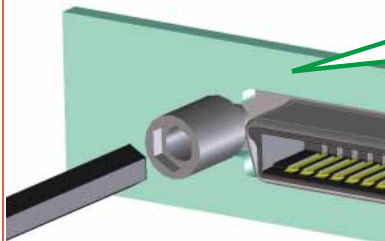

M2 screw

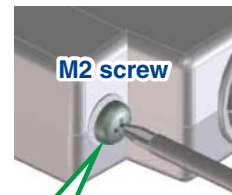

**Robust & Secure Screw Lock**  
Tightening torque: 0.06 to 0.07 N-m max

### 3. Excellent Shielding for EMI Prevention

#### ◆Grounding Structure

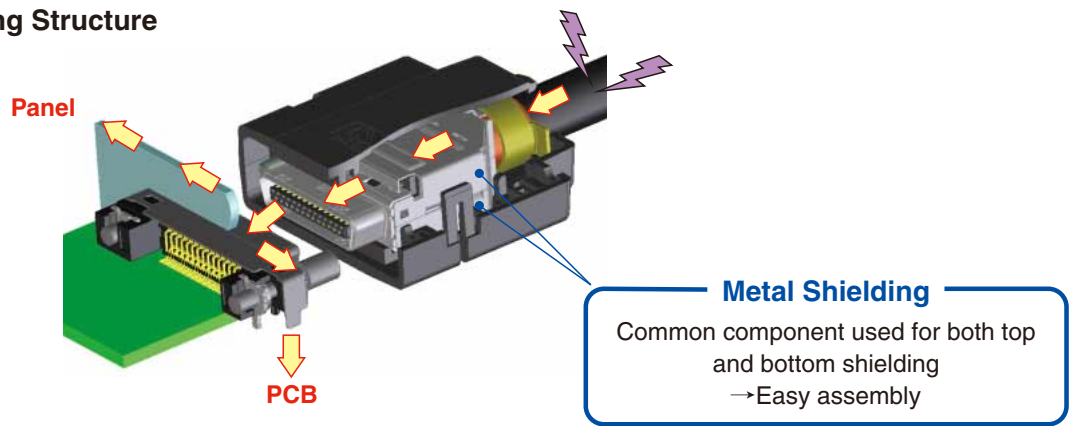

### 4. Wide variation

There are various variations corresponding to the usage.

#### ●Lock variation

Lock type	Cover case	receptacle			
Item	Specification /Part number	Item	Part number		
Screw lock	Screwdriver type DH-**-CV1B Hand-screw type DH-**-CV2B	Connector	DH60-**P / DH80-**P		
		Panel lock	Applicable panel thickness(mm)	Number of washers	Part No.
			1.4 to 1.6	0	DH-LNA
			0.9 to 1.2	1(t=0.4)	DH-LNA-W4
		0.5 to 0.8mm	1(t=0.6)	DH-LNA-W8	
		No panel	1(t=0.8)	DH-LNA-W16	
One touch lock	Metal button DH-**-CT1B Plastic button DH-**-CT2B	Connector	DH60A-**P / DH80A-**P		

\*Screw lock type and One touch lock type does not mate together.

#### ●Common part

Lock type	Plug				No. of pos.	Clamp metal Part No.
	Connector					
Item	Specification / Part number					
Screw lock	IDC type				17	DH-17-CMB(6.3)
	Cable spec.	Outer dia.	Construction	Part No.		
	Twinax cable	0.88 to 0.92	7/0.127	DH30B-**S	27	DH-27-CMB(6.9)
	Twisted pair cable	0.64 to 0.68	(AWG#28)	DH32B-**S		
	solder type DH40-**S (Developing Pin-variation of the above item is under planning.)				37	DH-37-CMB(8.8)
One touch lock	Please consult HRS sales.)				51	DH-51-CMB(9.6)

\*The figure in ( ) clamp part number is equal to the cable's outer diameter.

### 5. High Speed Data Transmission

This data is for reference only. The data can differ due to cable or PCB used in evaluation.

#### Eye Diagram [CH1-CH2]

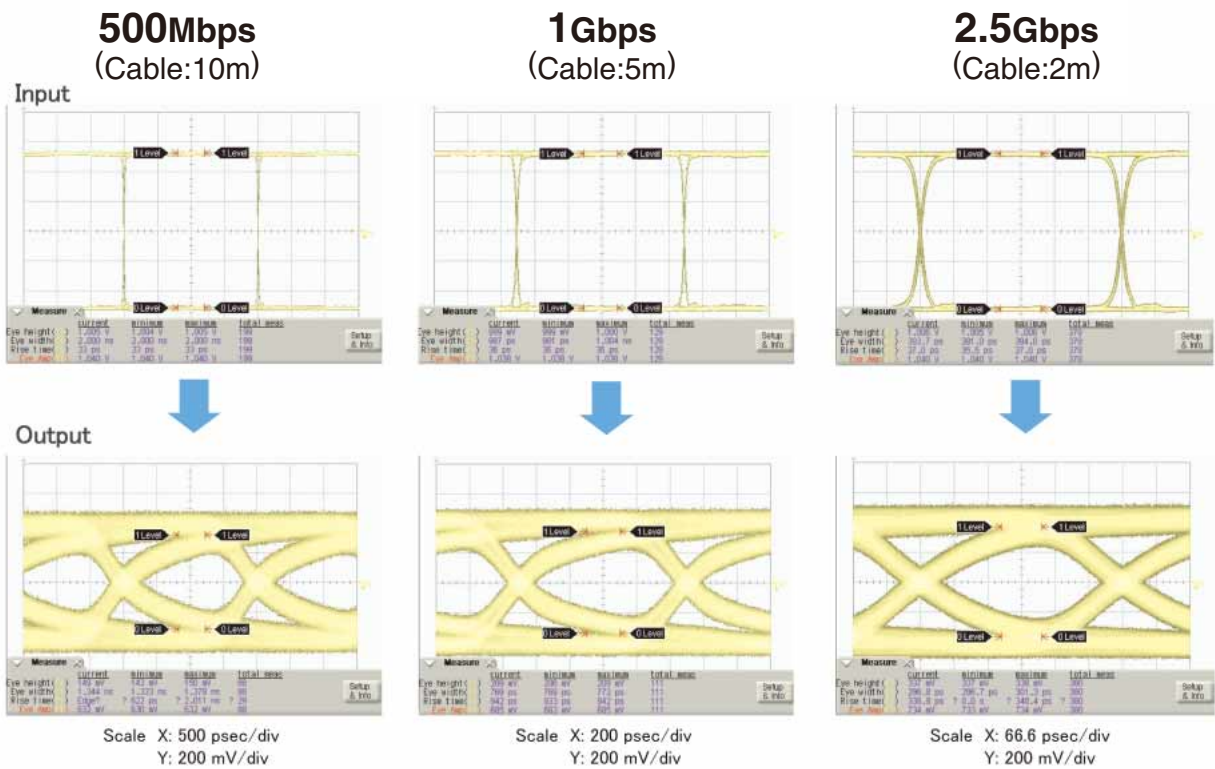

#### Measurement Condition

##### ◆ Pin Assignment

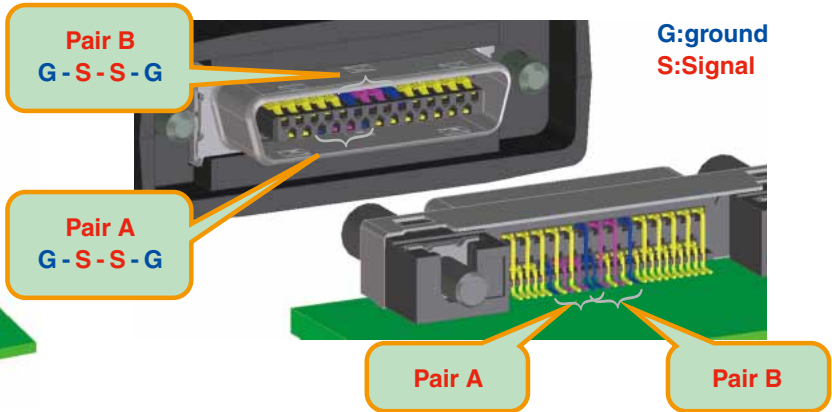

##### ◆ Measurement Condition

- Measurement Pair: Differential Pair A
- Cable: Twinax cable
- Input signal voltage: 500mV

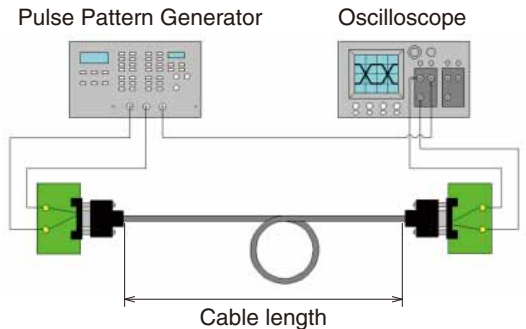

## Specifications

Ratings	Current rating	0.5A	Operating temperature range	-25°C to +85°C
	Voltage rating	125 V AC	Storage temperature range	-25°C to +60°C

Item	Specification	Conditions
1.Contact resistance	① 50mΩ max.(IDC type) 65mΩ max.(Solder type)	100mA(DC or 1,000Hz)
2.Insulation resistance	1000MΩ min.	100 V DC
3.Withstanding voltage	No flashover or insulation breakdown	250 V AC/1minute
4.Insertion and with drawal forces	17pos. 27pos. 37pos. 51pos.	Measured by applicable connector.
	Insertion f. 25N max. 30N max. 36N max. 43N max.	
	with drawal f. 2.6N min. 3N min. 3.3N min. 3.8N min.	
5.Durability	① Contact resistance:70mΩ max.(IDC type) 85mΩ max.(Solder type) ② No damage, cracks or parts dislocation.	1000 cycles
6.Vibration	① No electrical discontinuity of 10μs or longer. ② No damage, cracks or parts dislocation.	Frequency: 10 to 50Hz, single amplitude of 0.75mm, 5min/cycle, total 10 cycles.
7.Shock		Acceleration of 490m/s <sup>2</sup> , 11ms duration, sine half-wave waveform, 3 cycles in each of the 3 axis.
8.Temperature cycle	① Contact resistance:70mΩ max.(IDC type) 85mΩ max.(Solder type) ② No damage, cracks or parts dislocation.	Temperature: -55°C→+5°C to +35°C→+85°C→+5°C to +35°C Time:30→5→30→5(Minutes) 5cycles
9.Humidity (Steady state)	① Insulation resistance:100MΩ min. ② No damage, cracks or parts dislocation.	96 hours at 40°C And RH 90% to 95%.
10.Salt spray test	① Contact resistance:100mΩ max.	5% salt water solution for 48 hours.

① Excludes wire conductor resistance.

\*Unless otherwise specified, refer to JIS C 5402

## Materials

Products	Components	Material	Finish	Remarks
Screw lock type receptacle connector (DH60-***P / DH80-***P)	Insulator	Polyamide resin	Black	UL94V-0
	Contacts	Copper alloy	Selective gold plated	—
	Shell	Stainless steel	Tin plated	—
	Metal fitting	Stainless steel	Selective Tin plated	—
One Touch Lock Type Receptacle connector (DH60A-***P / DH80A-***P)	Insulator	Polyamide resin	Black	UL94V-0
	Contacts	Copper alloy	selective gold plated	—
	Shell	Stainless steel	Tin plated	—
	Metal fitting	Brass	Tin plated	—
	Metal grounding post	Steel	Nickel plated	—
Plug connector (DH3*B-***S)	Insulator	Polyamide resin	Black	UL94V-0
	Contacts	Copper alloy	Selective gold plated	—
	Rear insert	PBT resin	Black,Natural	UL94V-0
	Shell	Stainless steel	Nickel plated	—
Screw lock type cover case (DH-**-CV1B)	Cover	Polycarbonate resin	Black	UL94V-0
	Shield	Stainless steel	Nickel plated	—
	Screw lock	Steel	Nickel plated	—
	Tapping screw	Steel	Black chromate(Cr+3)	—
Lock type cover case (DH-**-CV2B)	Cover	Polycarbonate resin	Black	UL94V-0
	Shield	Stainless steel	Nickel plated	—
	Screw lock	Steel	Nickel plated	—
	Screw insulator	Polyamide resin	Black	UL94V-0
	Tapping screw	Steel	Black chromate(Cr+3)	—
One Touch Lock Type metal button cover case (DH-**-CT1B)	Cover	Polycarbonate resin	Black	UL94V-0
	Shield	Stainless steel	Nickel plated	—
	Lock spring	Stainless steel	—	—
	Tapping screw	Steel	Black chromate(Cr+3)	—
One Touch Lock Type plastic button cover case (DH-**-CT2B)	Cover	Polycarbonate resin	Black	UL94V-0
	Shield	Stainless steel	Nickel plated	—
	Lock spring	Stainless steel	—	—
	Button	Polycarbonate resin	Black	UL94V-0
	Tapping screw	Steel	Black chromate(Cr+3)	—
Lock screw (DH-LNA***)	Screw lock	Steel	Nickel plated	—
	Waher	Steel	Nickel plated	—
	Spring washer	Steel	Nickel plated	—
Metal clamp(DH-CMB(**))	Metal clamp	Brass	—	—

**Screw lock type**

**■ Receptacle connector**

**● Right angle type**

[17pos. DH60-17P]

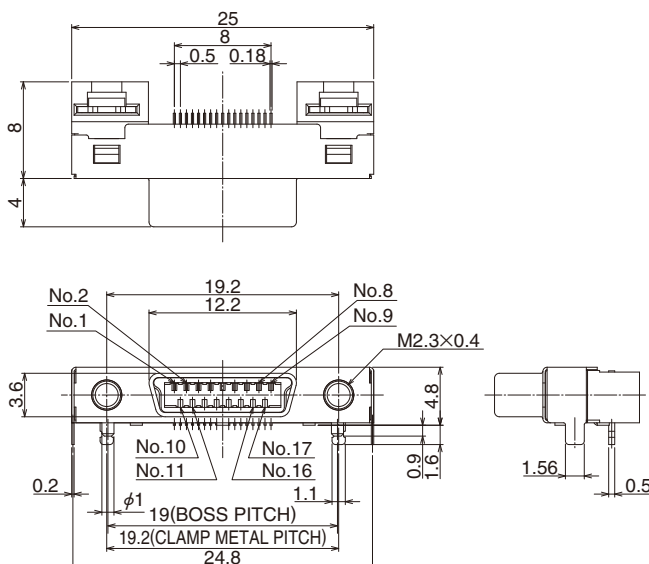

[27pos. DH60-27P]

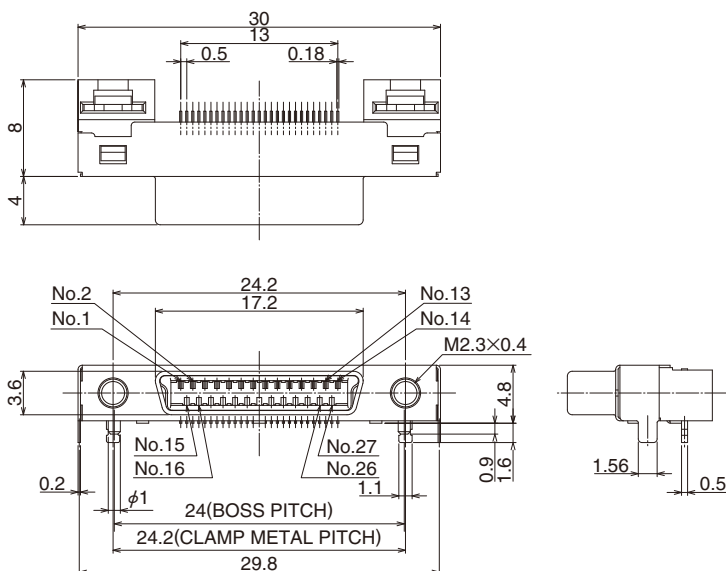

[37pos. DH60-37P]

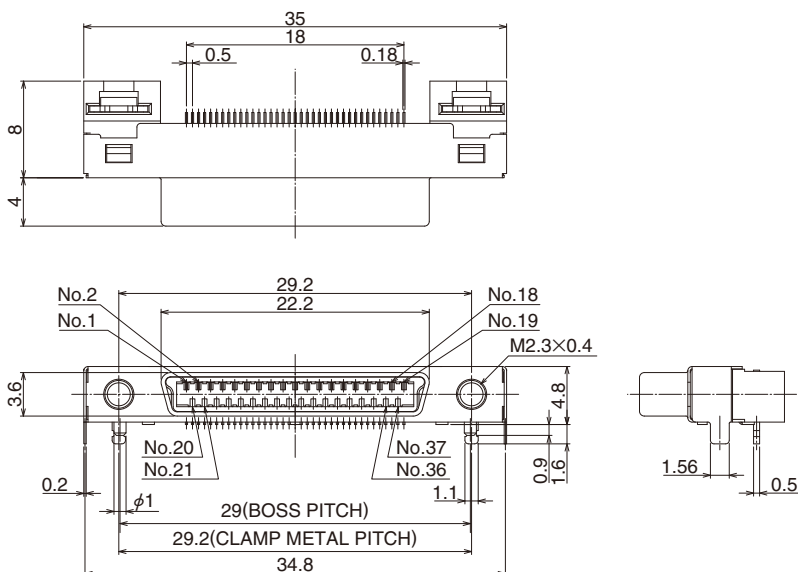

[51pos. DH60-51P]

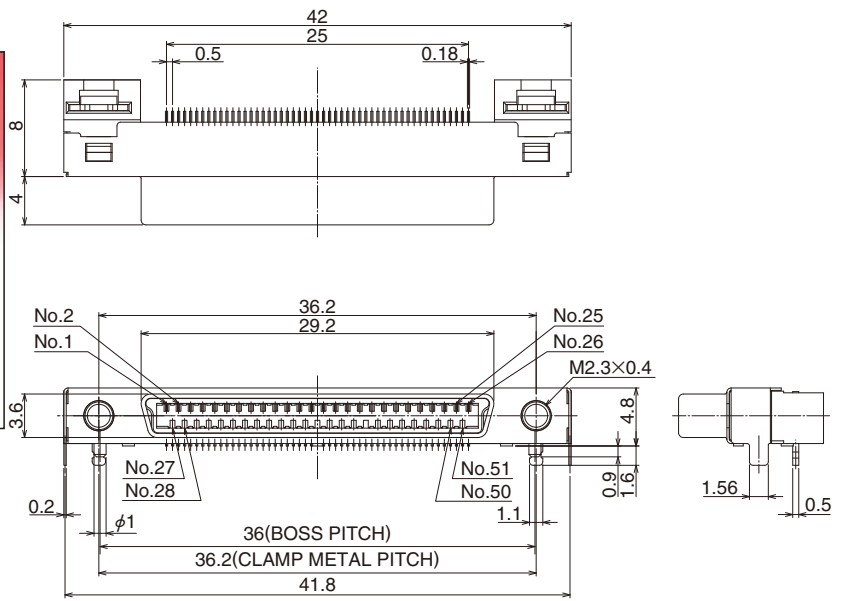

● Straight type

[27pos. DH80-27P]

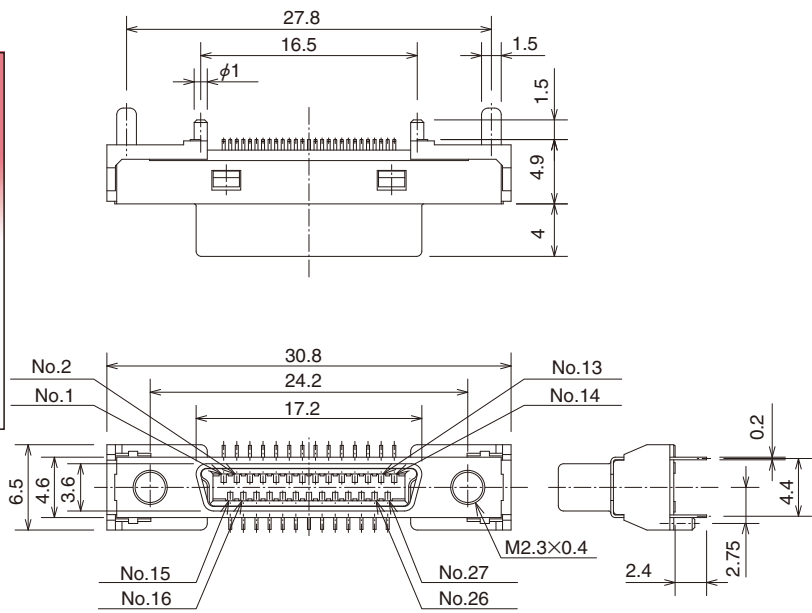
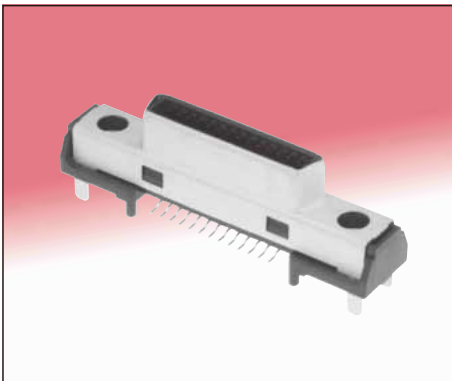

**Lock screw**

[Applicable panel thickness 1.4 to 1.6mm:DH-LNA]

[Applicable panel thickness 0.9 to 1.2mm:DH-LNA-W4]

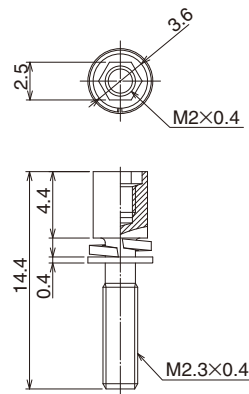
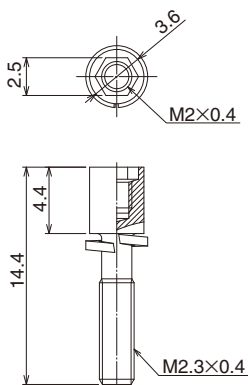

[Applicable panel thickness 0.5 to 0.8mm:DH-LNA-W8][No panel:DH-LNA-W16]

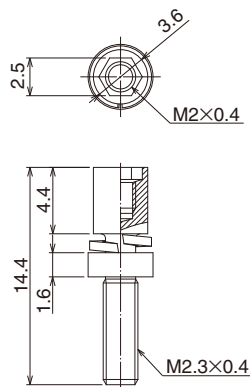
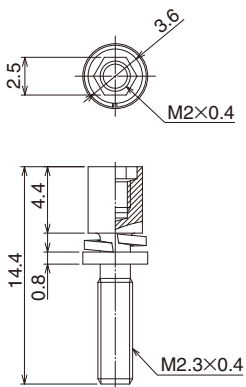

■ Cover case

● Screw lock

[17pos. DH-17-CV1B]



Note 1. This product is delivered separately.  
 ② A recommended screw tightening torque to lock screw(DH-LNA\*\*\* ) should be from 0.06 to 0.07N·m.  
 ③ A recommended screw tightening torque for covers to be from 0.1 to 0.15N·m.

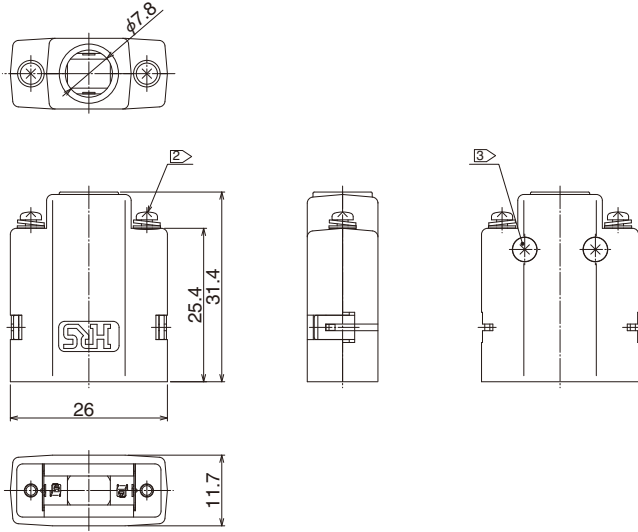

[27pos. DH-27-CV1B]

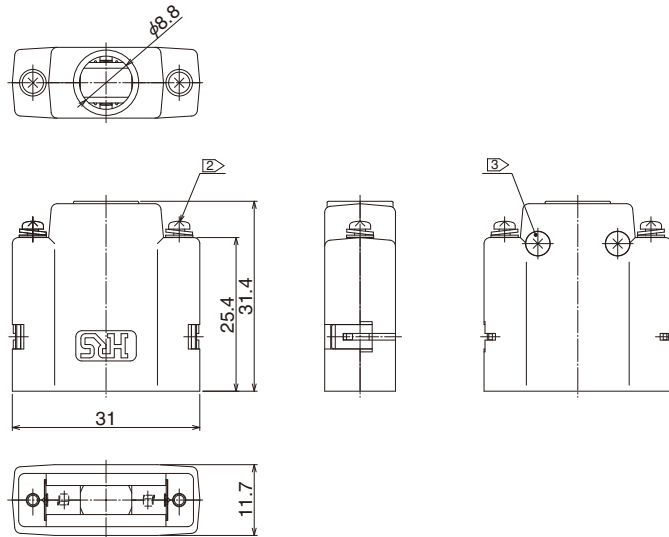



[37pos. DH-37-CV1B]

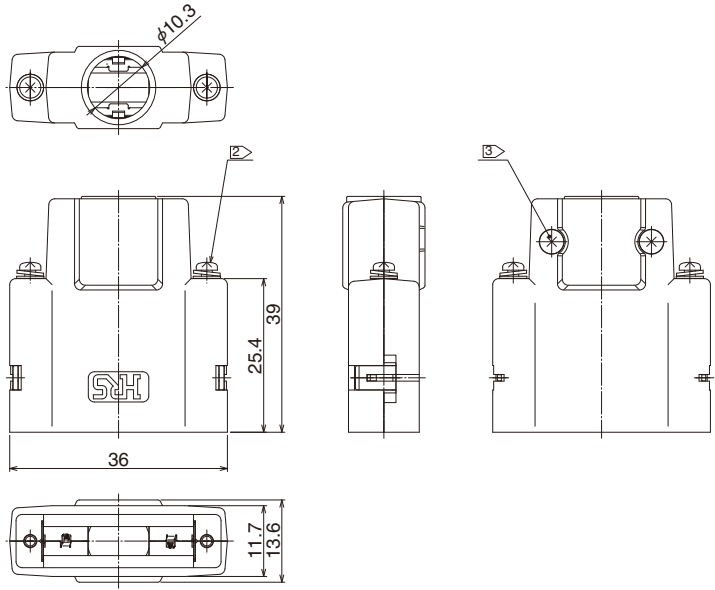

[51pos. DH-51-CV2B]

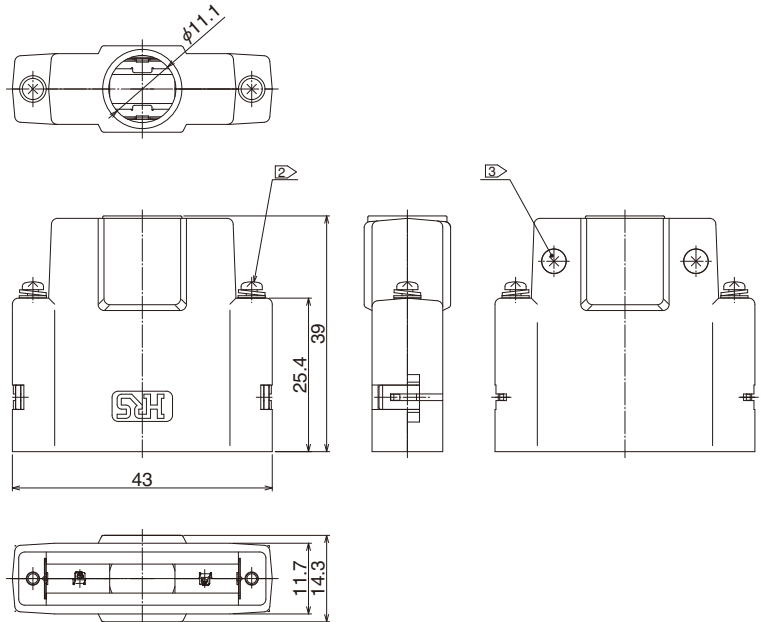

● Hand screw  
[17pos. DH-17-CV2B]

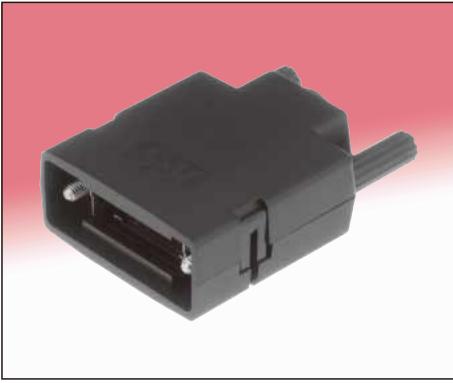

Note 1. This product is delivered separately.  
 ② A recommended screw tightening torque to the lock screws to be from 0.06 to 0.07N·m.  
 ③ A recommended screw tightening torque for covers to be from 0.1 to 0.15N·m.

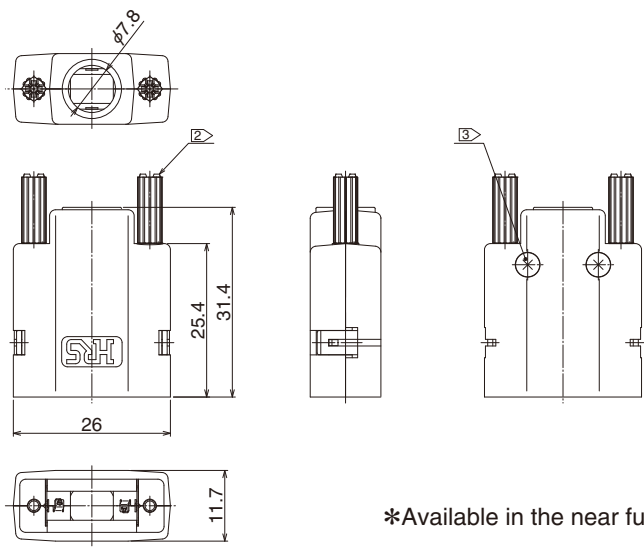

\*Available in the near future

[27pos. DH-27-CV2B]

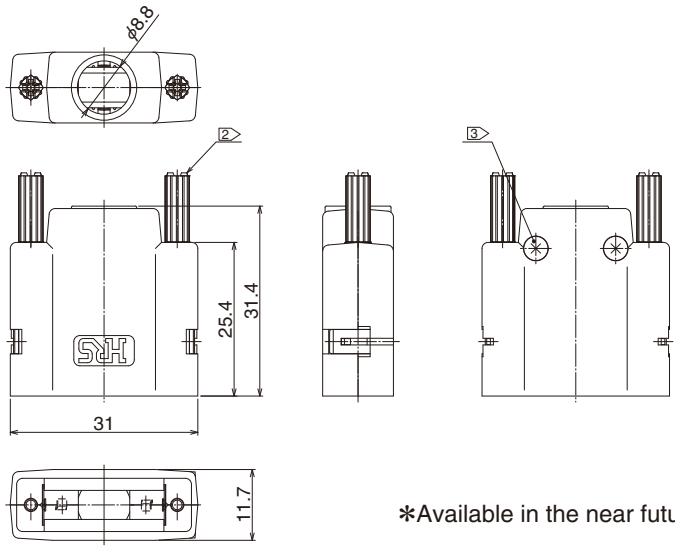
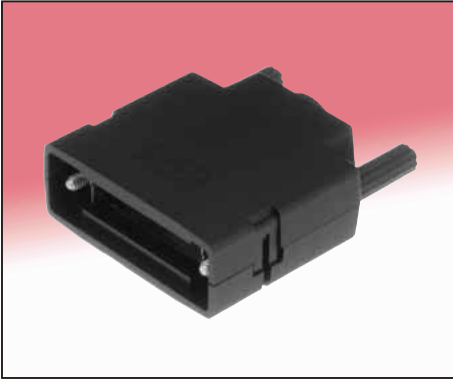

\*Available in the near future

Feb.1.2017 Copyright 2017 HIROSE ELECTRIC CO., LTD. All Rights Reserved.

[37pos. DH-37-CV2B]

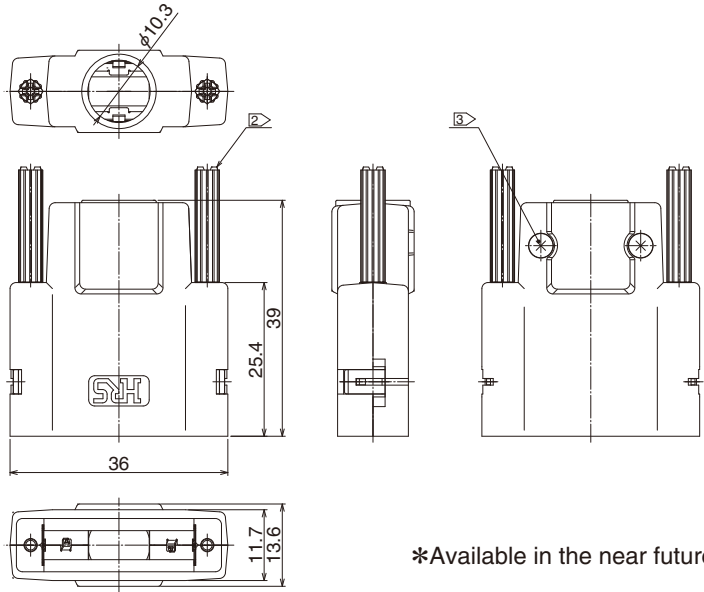

\*Available in the near future

[51pos. DH-51-CV2B]

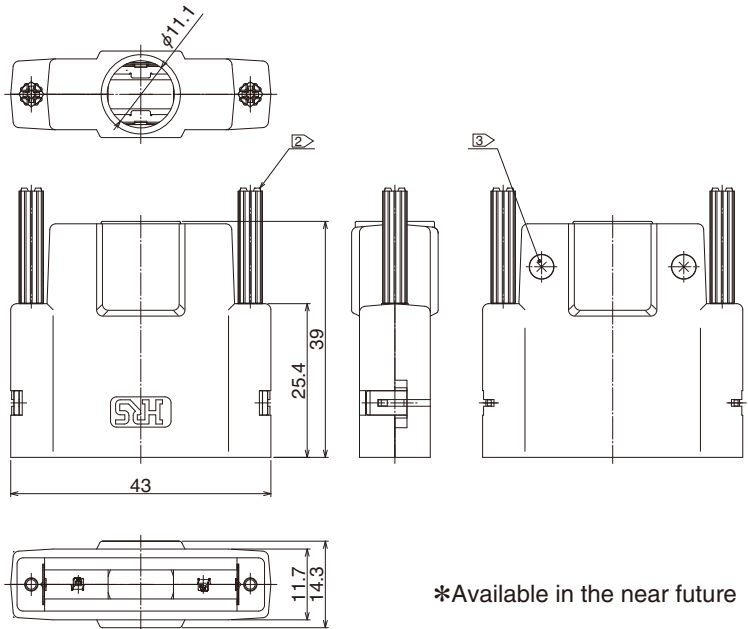
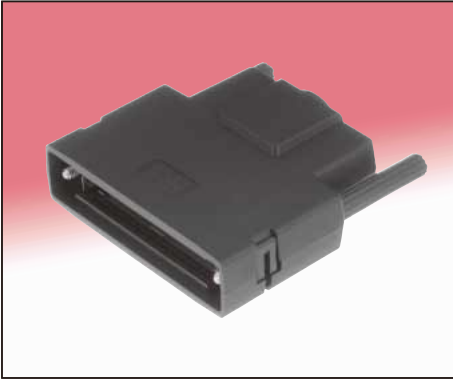

\*Available in the near future

## One Touch Lock Type

### ■ Receptacle connector

#### ● Right angle type

[17pos. DH60A-17P]

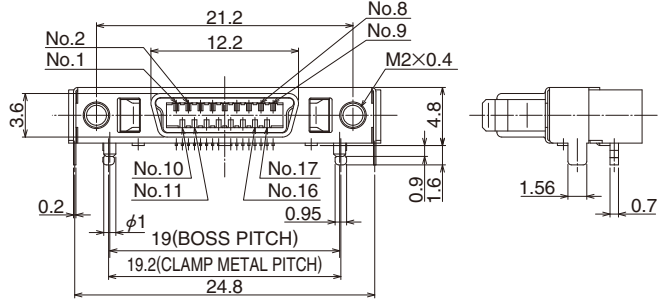
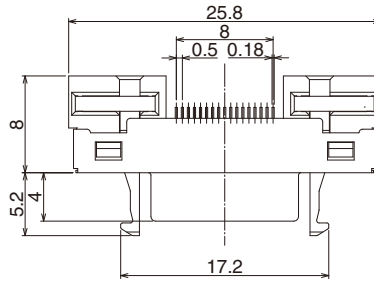

[27pos. DH60A-27P]

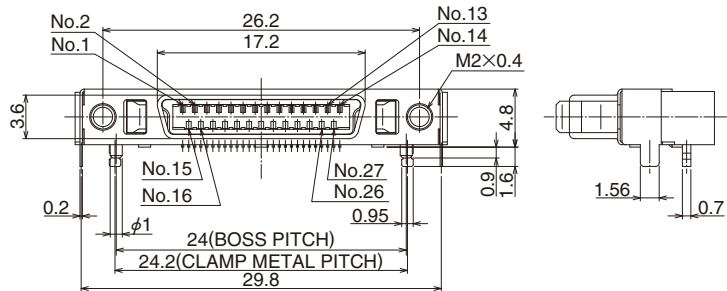
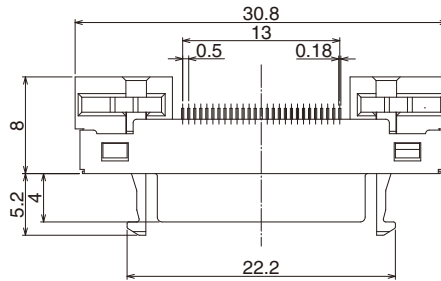

[37pos. DH60A-37P]

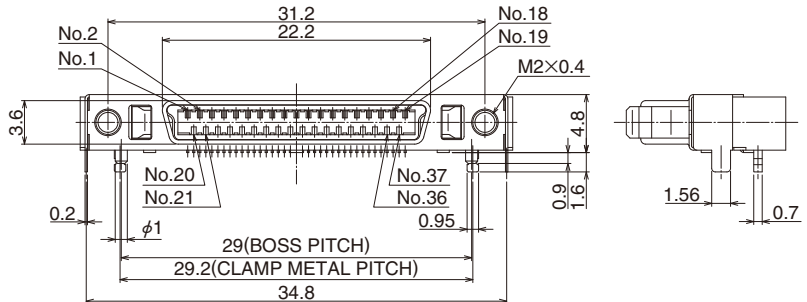
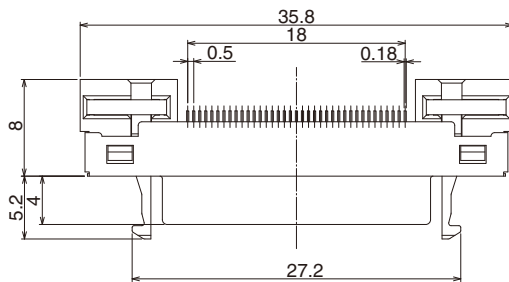

[51pos. DH60A-51P]

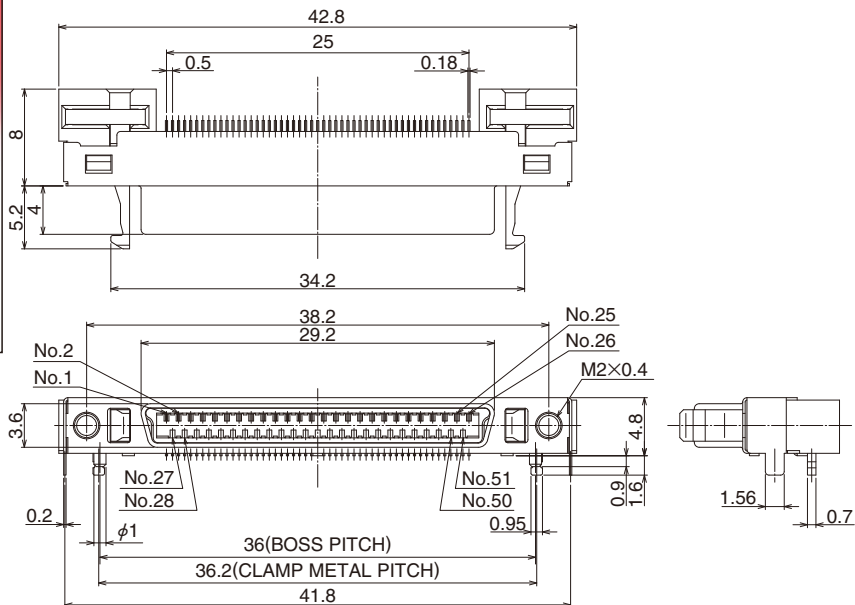

● Straight type

[27pos. DH80A-27P]

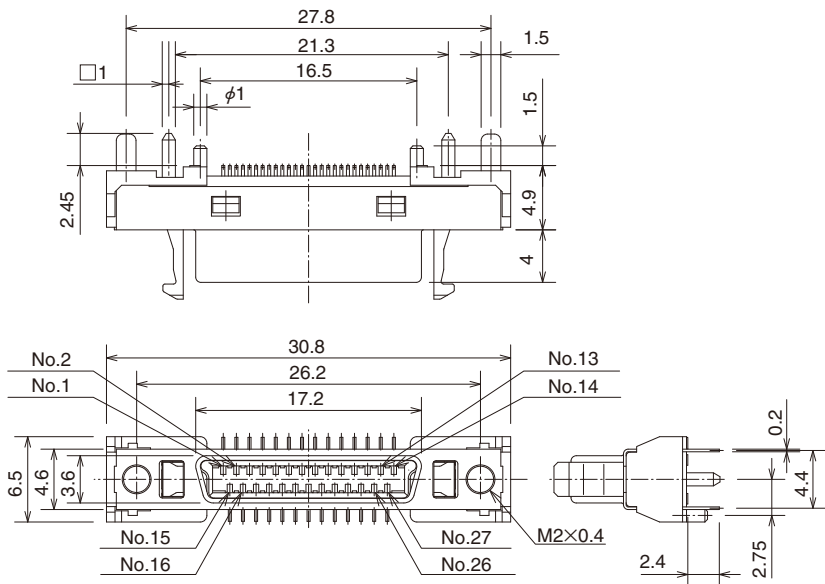
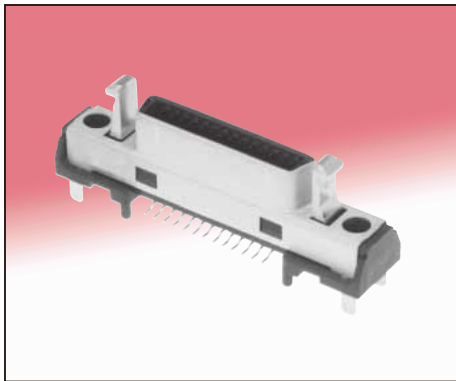

■ Cover case

● Metal button type

[17pos. DH-17-CT1B]



Note 1. This product is delivered separately.

② A recommended screw tightening torque for covers to be from 0.1 to 0.15N·m.

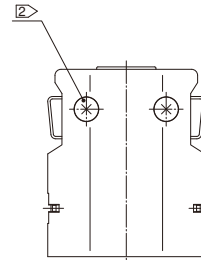
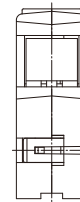
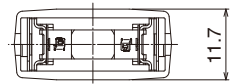
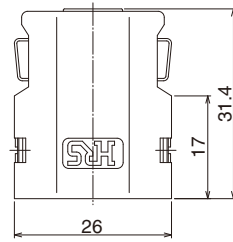
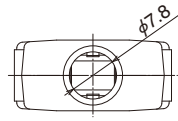

[27pos. DH-27-CT1B]

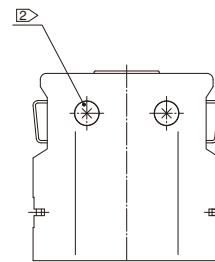
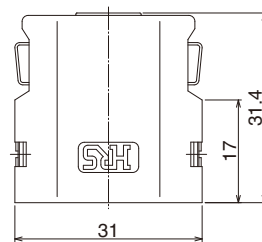
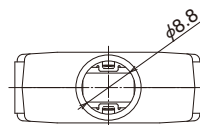

[37pos. DH-37-CT1B]

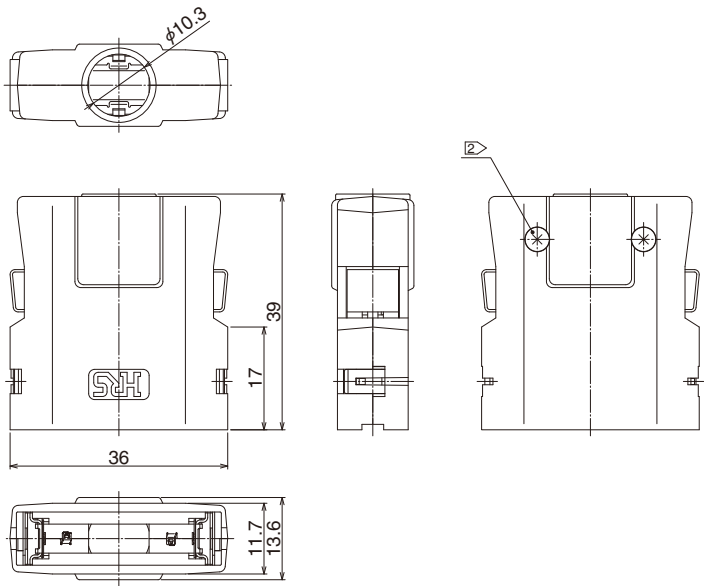

[51pos. DH-51-CT1B]

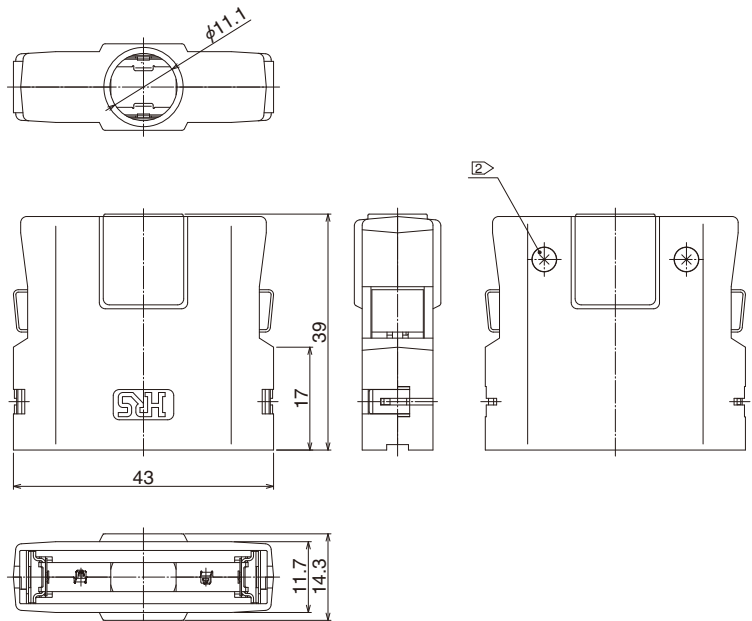

● Plastic button type  
[17pos. DH-17-CT2B]

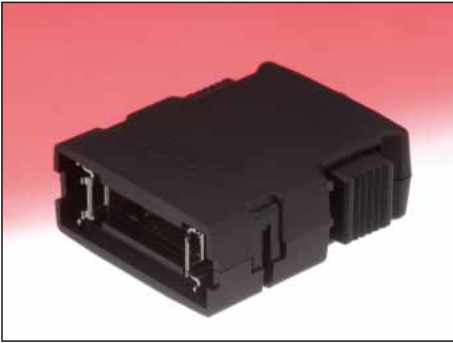

Note 1. This product is delivered separately.  
② A recommended screw tightening torque for covers to be from 0.1 to 0.15N·m.

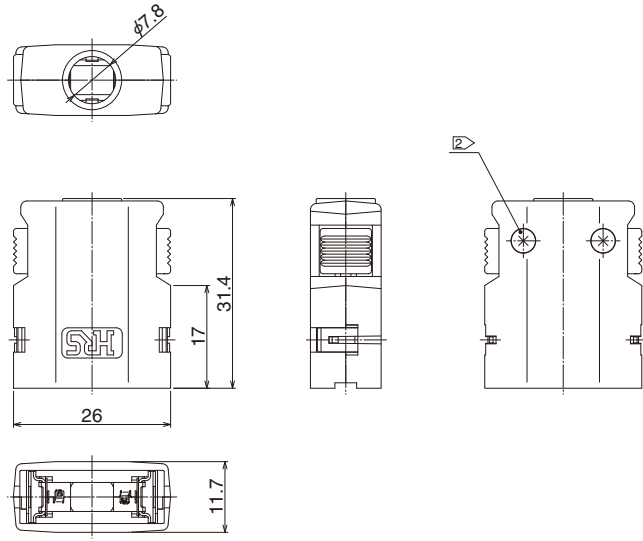

[27pos. DH-27-CT2B]

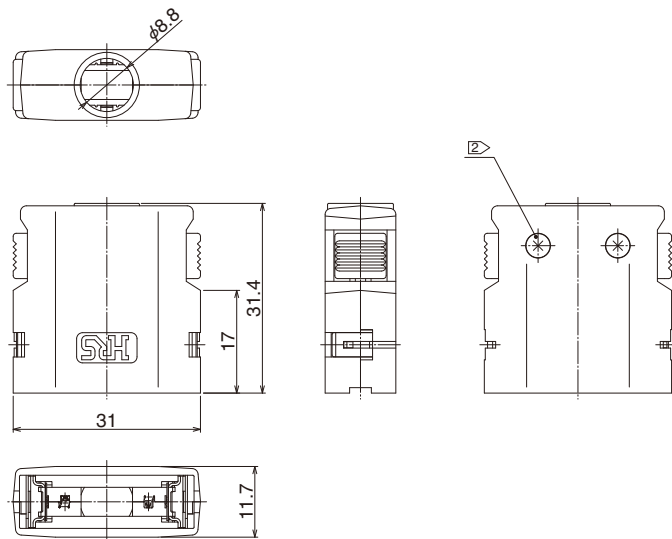



[37pos. DH-37-CT2B]

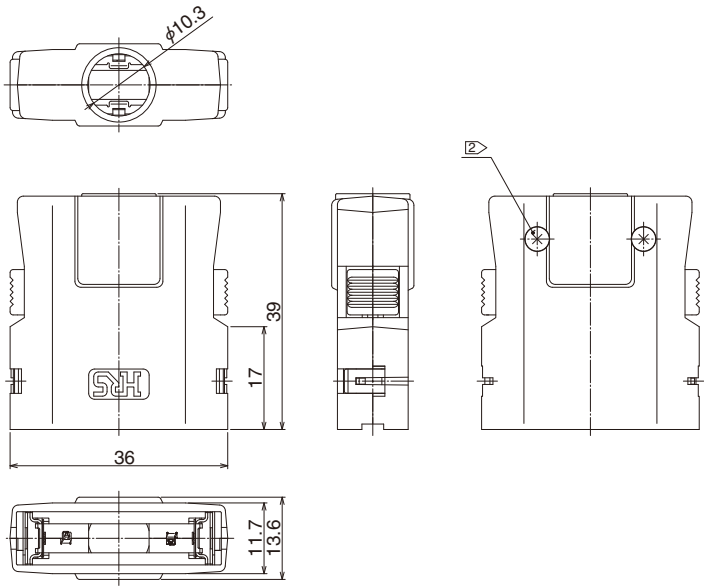

[51pos. DH-51-CT2B]

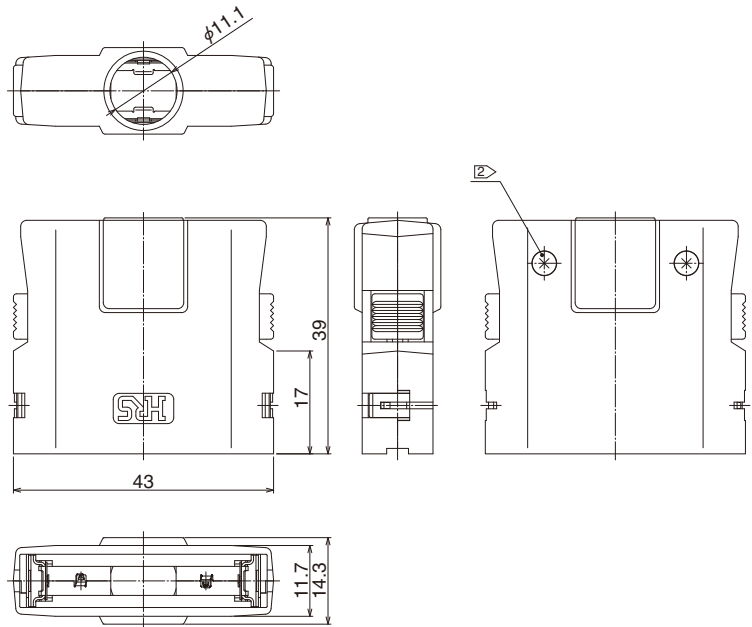

## ■ Plug unit

### ● IDC type

[17pos. DH30B-17S]

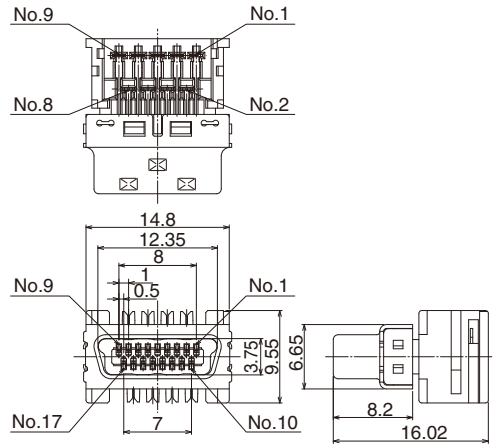

### Bundled parts

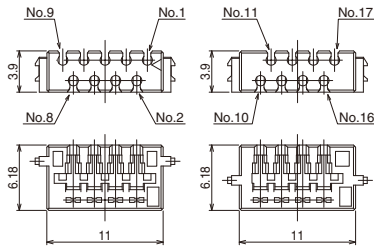

[27pos. DH30B-27S, DH32B-27S]

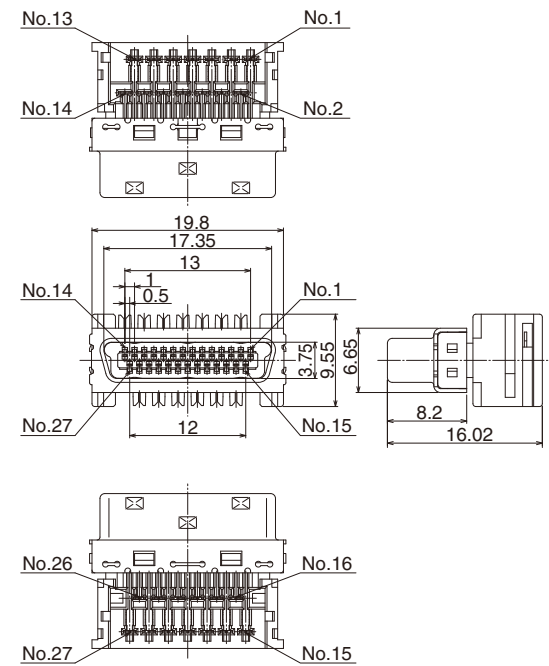

### Bundled parts

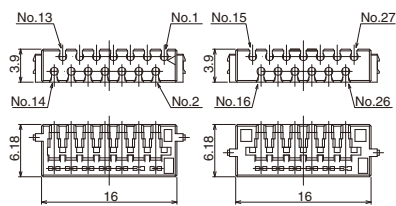

\*Hole diameter in the holder for DH30B-27S and DH32B-27S are different.

[37pos. DH30B-37S]

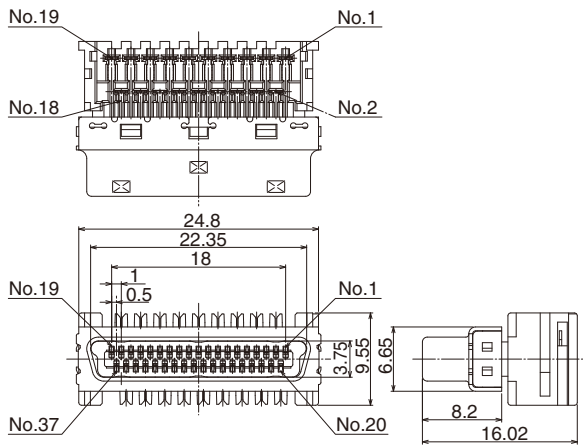

Bundled parts

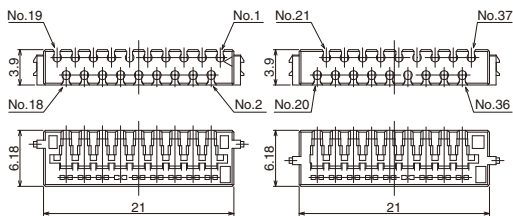

[51pos. DH30B-51S]

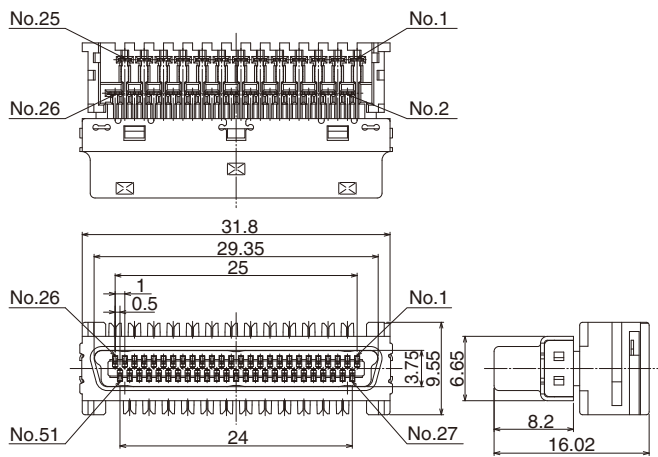

Bundled parts

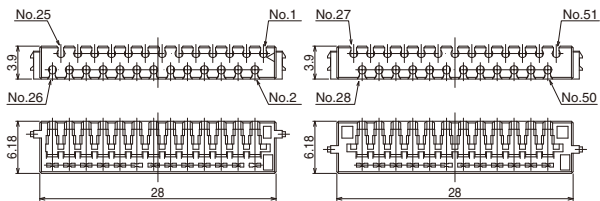

● Solder contact type

[27pos. DH40-27S]

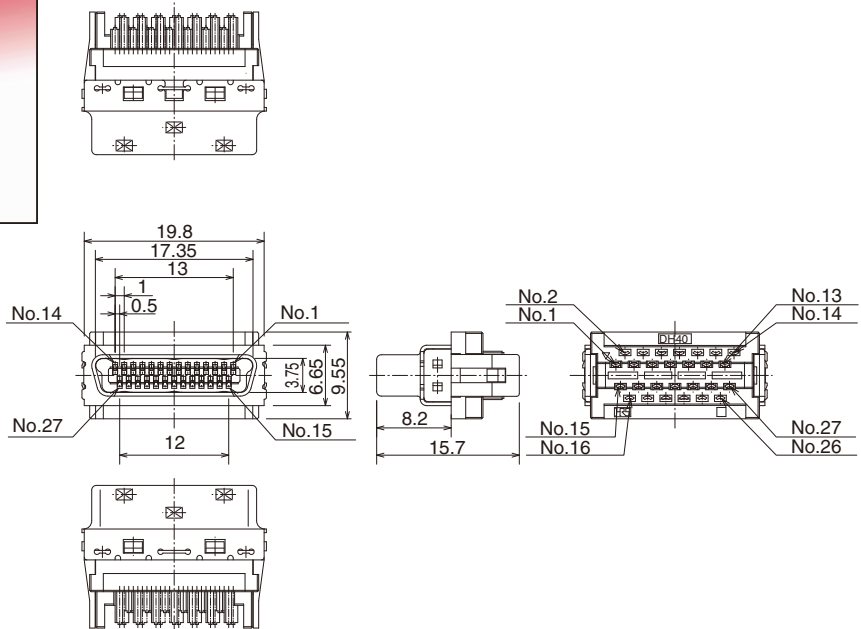
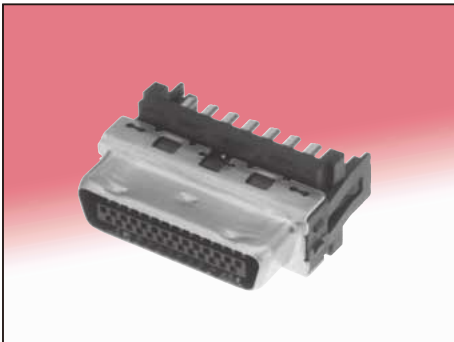

[37pos. DH40-37S]

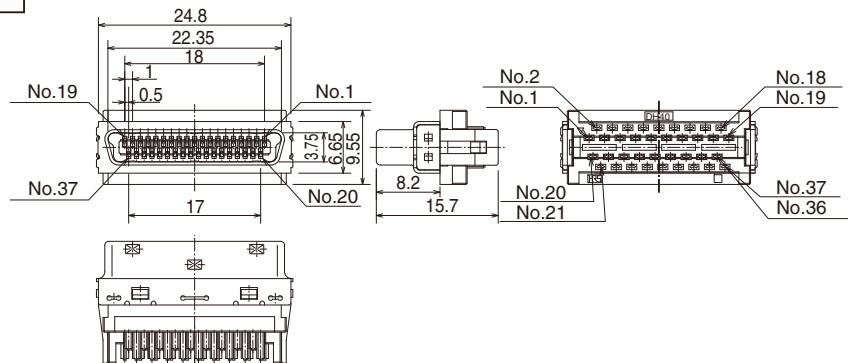
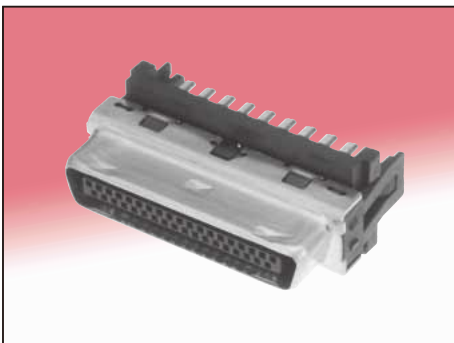

**■Metal clamp**

**[17pos. DH-17-CMB(6.3)]**  
**(Cable outer diameter 6.3mm)**

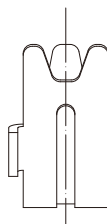
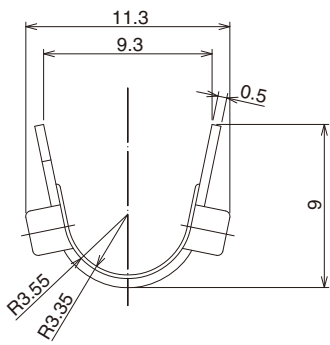
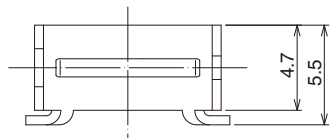

**[27pos. DH-27-CMB(6.9)]**  
**(Cable outer diameter 6.9mm)**

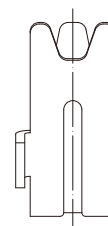
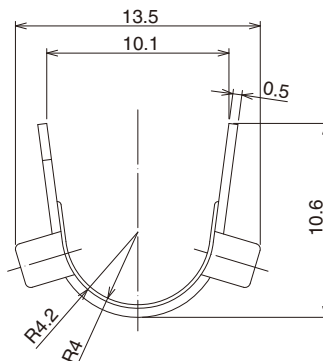
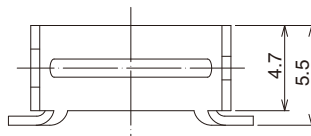

**[27pos. DH-27-CMB(7.3)]**  
**(Cable outer diameter 7.3mm)**

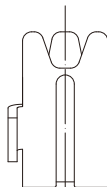
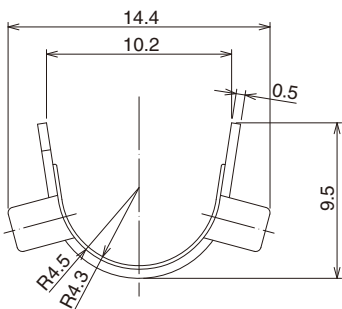
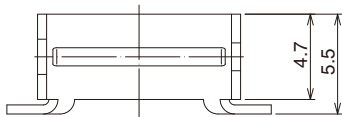

**[37pos. DH-37-CMB(8.8)]**  
**(Cable outer diameter 8.8mm)**

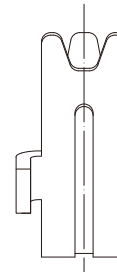
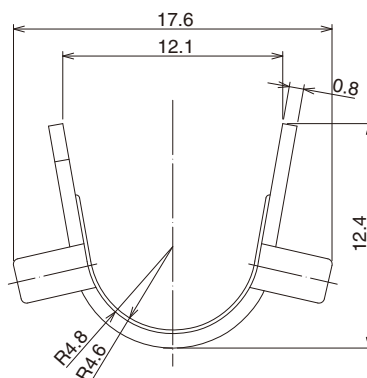
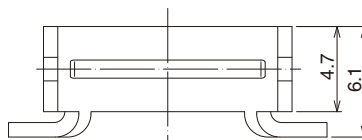

Feb.1.2017 Copyright 2017 HIROSE ELECTRIC CO., LTD. All Rights Reserved.

[51pos. DH-51-CMB(9.6)]  
(Cable outer diameter 9.6mm)

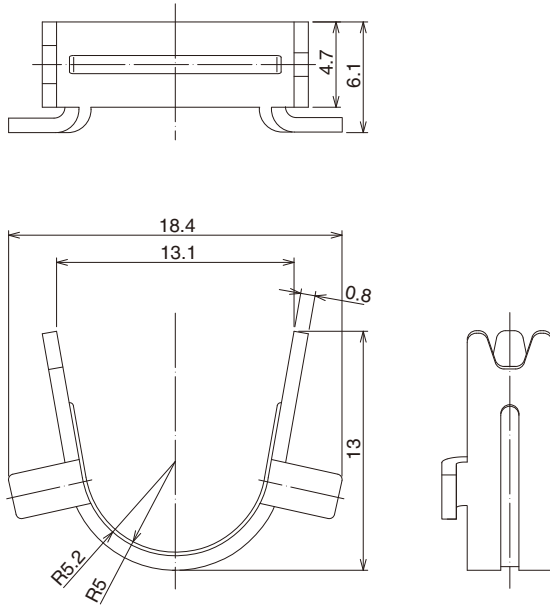

**Recommended PCB Mounting pattern**

**DH60-\*\*\*P, DH60A-\*\*\*P**

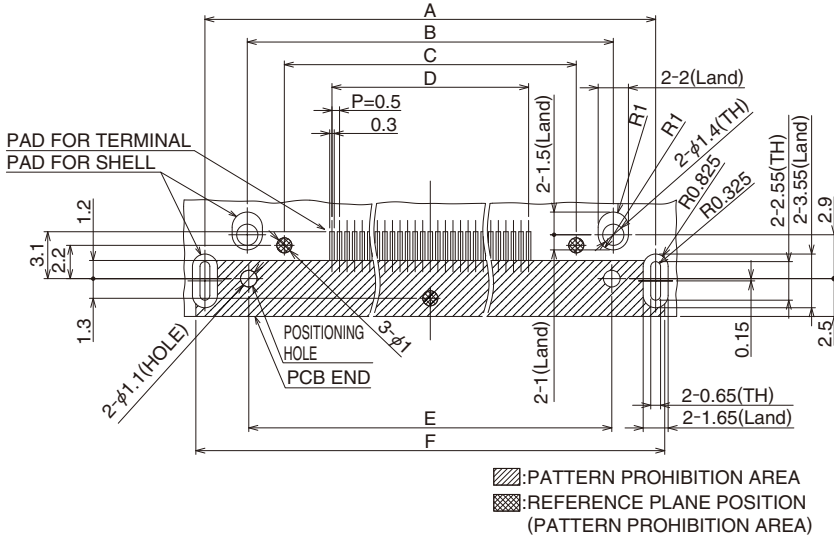

Unit:mm

	A	B	C	D	E	F
DH60-17P	24.8	19.2	14.3	8	19	26
DH60A-17P						
DH60-27P	29.8	24.2	19.3	13	24	31
DH60A-27P						
DH60-37P	34.8	29.2	24.3	18	29	36
DH60A-37P						
DH60-51P	41.8	36.2	31.3	25	36	43
DH60A-51P						

**DH80-27P**

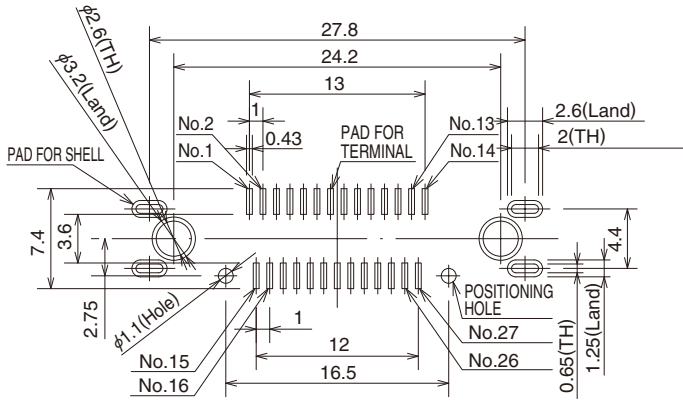

**DH80A-27P**

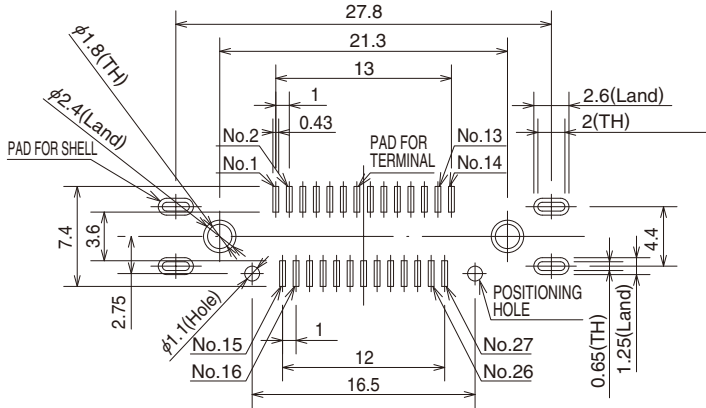

**Terminal No.chart**

**DH60-\*\*\*P, DH60A-\*\*\*P**

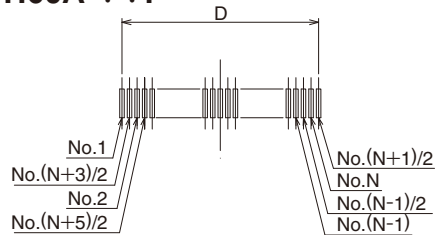

\*N: Number of positions

■ Panel cutout

● Screw lock type

Panel cutout for reference (Right angle type, Straight type)

(The dimension is specified based on the center of the connector interface)

DH- NA(C 244-0045-0-00)

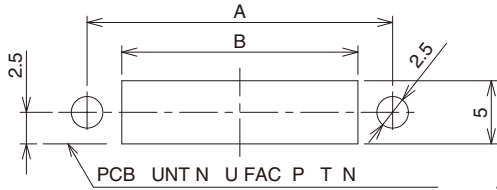

\*Please set piercing R as less than R1.

DH- NA- 4(C 244-0046-2-00)

DH- NA- 8(C 244-0004-2-00)

DH- NA- 16(C 244-0005-5-00)

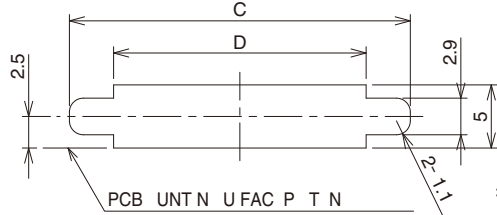

\*Please set piercing R as less than R1.

A·B·C·D dimension table

Unit:mm

Number of contacts	A	B	C	D
17	19.2	13.7	22	15
27	24.2	18.7	27	20
37	29.2	23.7	32	25
51	36.2	30.7	39	32

Connector mounted on PCB

(For example, panel thickness is 1.6mm)

\*The drawing is shown sample of DH60-27P.

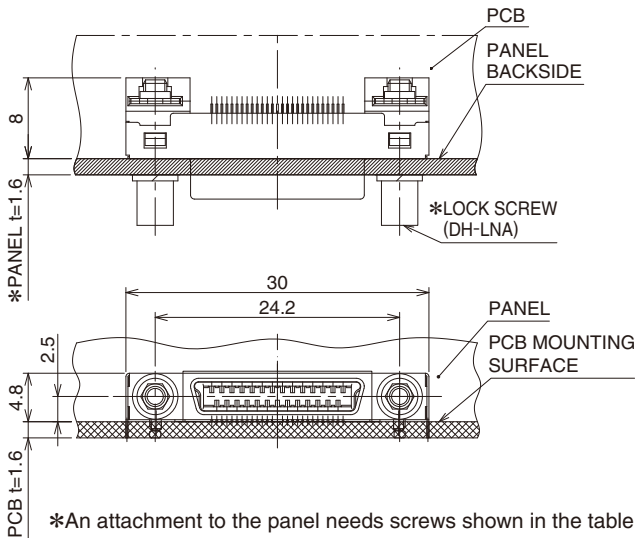

\*An attachment to the panel needs screws shown in the table below.

Applicable panel thickness(mm)	Part No.	Code No.
1.4 to 1.6	DH-LNA	244-0045-0-00
0.9 to 1.2	DH-LNA-W4	244-0046-2-00
0.5 to 0.8	DH-LNA-W8	244-0004-2-00
No panel	DH-LNA-W16	244-0005-5-00

\*The recommended screw tightening torque to be from 0.12 to 0.3 N·m

\*DH80-27P

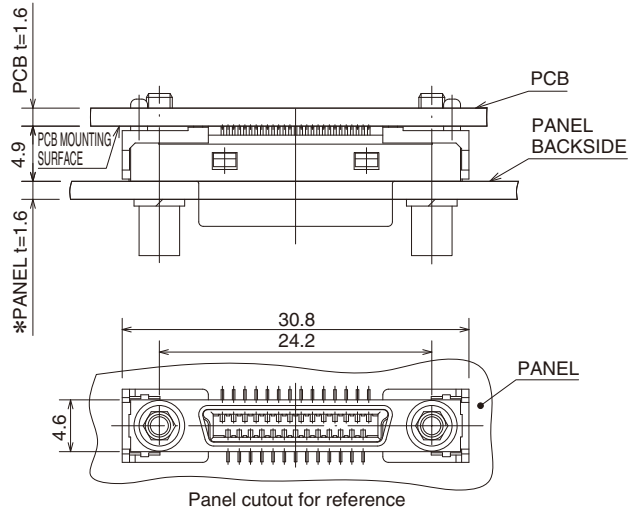



●One Touch Lock Type

Panel cutout for reference (Right angle type, Straight type)

(The dimension is specified based on the center of the connector interface)

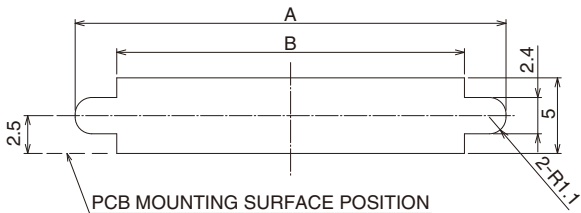

\*Please set the draft R for process as max R1.

A·B dimension table

Unit:mm

Number of contacts	A	B
17	23.5	18
27	28.5	23
37	33.5	28
51	40.5	35

Connector mounted on PCB

\*DH60A-27P is representative examples.

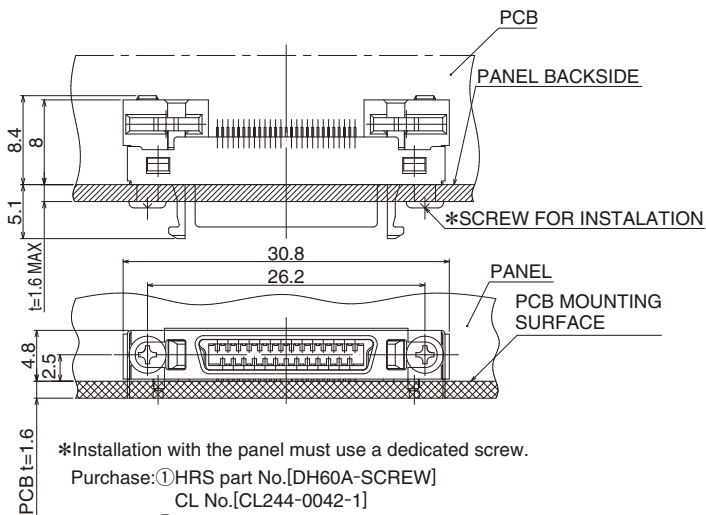

\*Installation with the panel must use a dedicated screw.

Purchase: ①HRS part No.[DH60A-SCREW]  
 CL No.[CL244-0042-1]  
 ②NITTOSEIKO Co., Ltd.  
 [FINE PAN HEAD MACHINE SCREW 2 TYPES]

\*SCREW FOR INSTALLATION

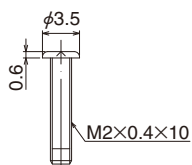

\*DH80A-27P

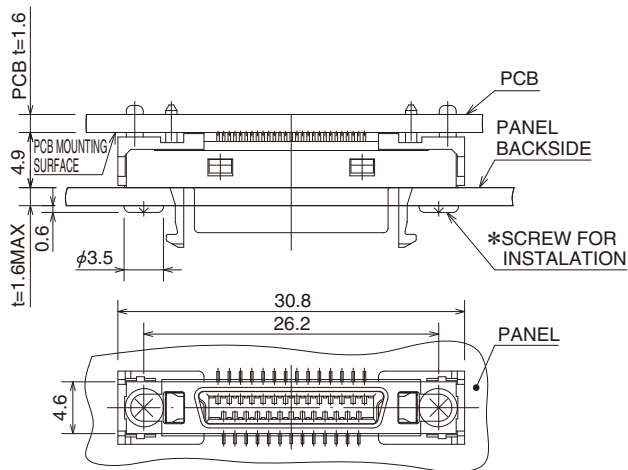

\*Installation with the panel must use a dedicated screw.

Purchase: ①HRS part No.[DH80A-SCREW]  
 CL No.[CL244-0059-4]  
 ②NITTOSEIKO Co., Ltd.  
 [FINE PAN HEAD MACHINE SCREW 2 TYPES]

\*SCREW FOR INSTALLATION

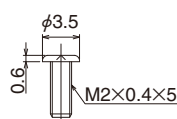

■Applicable tools

	Process	Part No.	CL No.
1	Cable end processing	manual work	
2	Upper level wire arranging	wire arranging tool : DH/CA-MO	CL902-2183-0
3	Upper level press fitting		
4	Lower level wire arranging		
5	Lower level press fitting		
6	Cable cutting	manual work(nipper etc.)	
7	IDC	① IDC-clamping tool:DH/IDCK-MP	CL902-2185-5
		② attachment for 17pos:DH-17UNIT	CL902-2186-8
		attachment for 27pos:DH-27UNIT	CL902-2187-0
		attachment for 37pos:DH-37UNIT	CL902-2188-3
		attachment for 51pos:DH-51UNIT	CL902-2189-6
		③ HI-FLEX termination press (Select appropriate attachment of each pin count from ②.)	CL550-0082-2
8	Cable clamping	① IDC-clamping tool:DH/IDCK-MP	CL902-2185-5
		② attachment for DH-17-CMB(6.3):DH-17-CMB(6.3)UNIT	CL902-2190-5
		attachment for DH-27-CMB(6.9):DH-27-CMB(6.9)UNIT	CL902-2194-6
		attachment for DH-27-CMB(7.3):DH-27-CMB(7.3)UNIT	CL902-2191-8
		attachment for DH-37-CMB(8.8):DH-37-CMB(8.8)UNIT	CL902-2192-0
		attachment for DH-51-CMB(9.6):DH-51-CMB(9.6)UNIT	CL902-2193-3
		③ HI-FLEX termination press (Select appropriate attachment of each pin count from ②.)	CL550-0082-2
9	Cover attaching	manual work(torque driver etc.)	

\*Customers already having HI-FLEX termination press can apply it to this product assembly.

\*Each ① and ③ of 7. IDC and 8. Clamping are the same tools. All the parts ①, ② and ③ are required for each 7. IDC and 8. Clamping processes for mass-production.



**USA:**

**HIROSE ELECTRIC (U.S.A.), INC. Headquarters**  
 2688 Westhills Court, Simi Valley, CA 93065-6235  
 Phone : +1-805-522-7958  
 Fax : +1-805-522-3217  
<http://www.hiroseusa.com>

**USA:**

**HIROSE ELECTRIC (U.S.A.), INC. San Jose Office**  
 3255 Scott Boulevard, Building 7, Suite 101  
 Santa Clara, CA 95054  
 Phone : +1-408-253-9640  
 Fax : +1-408-253-9641  
<http://www.hiroseusa.com>

**USA:**

**HIROSE ELECTRIC (U.S.A.), INC. Detroit Office (Automotive)**  
 37677 Professional Center Drive, Suite #100C  
 Livonia, MI 48154  
 Phone : +1-734-542-9963  
 Fax : +1-734-542-9964  
<http://www.hiroseusa.com>

**THE NETHERLANDS:**

**HIROSE ELECTRIC EUROPE B.V.**  
 Hogehillweg #8 1101 CC Amsterdam Z-O  
 Phone : +31-20-6557460  
 Fax : +31-20-6557469  
<http://www.hiroseeurope.com>

**GERMANY:**

**HIROSE ELECTRIC EUROPE B.V. German Branch**  
 Herzog-Carl-Strasse 4 D-73760 Ostfildern  
 (Scharnhauser Park)  
 Phone : +49-711-4560-02-1  
 Fax : +49-711-4560-02-299  
<http://www.hirose.de>

**UNITED KINGDOM:**

**HIROSE ELECTRIC EUROPE B.V. UK Branch**  
 22 Vincent Avenue, Crownhill Business  
 Centre, Crownhill, Milton Keynes, MK8 0AB  
 Phone : +44-1908-305750  
 Fax : +44-1908-305768  
<http://www.hirose.co.uk>

**CHINA:**

**HIROSE ELECTRIC TRADING (SHANGHAI) CO., LTD.**  
 1601, Henderson Metropolitan, NO.300, East Nanjing  
 Road, Huangpu District, Shanghai, China 200001  
 Phone : +86-21-6391-3355  
 Fax : +86-21-6391-3335  
<http://www.hirose-china.com.cn>

**CHINA:**

**HIROSE ELECTRIC TRADING (SHANGHAI) CO., LTD. Beijing Branch**  
 A1001, Ocean International Center, Building 56# East 4th  
 Ring Middle Road, Chao Yang District, Beijing, 100025  
 Phone : +86-10-5165-9332  
 Fax : +86-10-5908-1381  
<http://www.hirose-china.com.cn>

**CHINA:**

**HIROSE ELECTRIC TECHNOLOGIES (SHENZHEN) CO., LTD.**  
 Room 09-13, 19/F, Office Tower Shun Hing Square, Di Wang Commercial Centre  
 5002, ShenNanDong Road, ShenZhen City, Guangdong Province, 518008  
 Phone : +86-755-8207-0851  
 Fax : +86-755-8207-0873  
<http://www.hirose-china.com.cn>

**HONG KONG:**

**HIROSE ELECTRIC HONGKONG TRADING CO., LTD.**  
 Room 1001, West Wing, Tsim Sha Tsui Centre, 66  
 Mody Road, Tsim Sha Tsui East, Kowloon, Hong Kong  
 Phone : +852-2803-5338  
 Fax : +852-2591-6560  
<http://www.hirose-hongkong.com.hk>

**TAIWAN:**

**HIROSE ELECTRIC TAIWAN CO., LTD.**  
 103 8F, No.87, Zhengzhou Rd., Taipei  
 Phone : +886-2-2555-7377  
 Fax : +886-2-2555-7350  
<http://www.hirose-taiwan.com.tw>

**KOREA:**

**HIROSE KOREA CO., LTD.**  
 1261-10, Jeoungwhang-Dong, Shihung-City,  
 Kyunggi-Do 429-450  
 Phone : +82-31-496-7000, 7124  
 Fax : +82-31-496-7100  
<http://www.hirose.co.kr>

**SINGAPORE:**

**HIROSE ELECTRIC SINGAPORE PTE. LTD.**  
 10 Anson Road #26-1 International Plaza  
 079903  
 Phone : +65-6324-6113  
 Fax : +65-6324-6123  
<http://www.hirose-singapore.com.sg>

**INDIA:**

**HIROSE ELECTRIC SINGAPORE PTE. LTD. Bangalore Liaison office**  
 Unit No.03, Ground Floor, Explorer Building International Tech  
 Park Whitefield Road, Bangalore 560066 Karnataka, India  
 Phone : +65-6324-6113  
 Fax : +65-6324-6123  
<http://www.hirose-singapore.com.sg>

**INDIA:**

**HIROSE ELECTRIC SINGAPORE PTE. LTD Delhi Liaison Office**  
 Suite No. 606 5th Floor SB Tower 1A/1 Sector  
 16 A Filmcity Noida 201301 Uttar Pradesh-India  
 Phone : +91-120-4804917  
 Fax : +91-120-4804949  
<http://www.hirose.com/sg/>

**MALAYSIA:**

**HIROSE ELECTRIC SINGAPORE PTE. LTD (Representative office)**  
 1-10-07, Suntech @ Penang Cybercity (1164), Lintang  
 Mayang Pasir 3, 11950, Bayan Baru, Penang, Malaysia.  
 Phone : +604-619-2564  
 Fax : +604-619-2574  
<http://www.hirose.com/sg/>



**HIROSE ELECTRIC CO.,LTD.**

6-3, Nakagawa Chuoh-2-Chome, Tsuzuki-Ku, Yokohama-Shi 224-8540, JAPAN  
 TEL: +81-45-620-3526 Fax: +81-45-591-3726  
<http://www.hirose.com>  
<http://www.hirose-connectors.com>